

DC MOTOR

60W
~200W

□90mm

DIMENSIONS

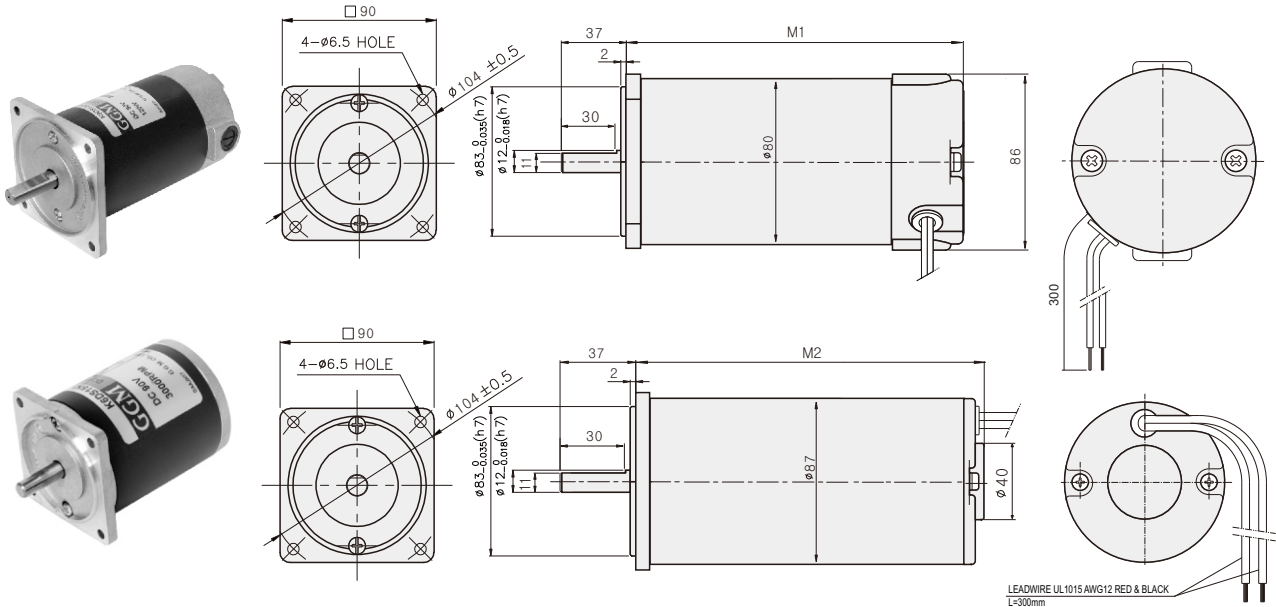

CONNECTION DIAGRAMS

RED ← ⊕ CW
BLACK ← ⊕ CCW

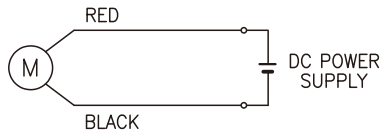

회전방향은 출력축에서 볼경우

치수도표

M1	∅	MOTOR	M2	∅	MOTOR
143	80	K9D□60N□ K9D□90N□	170	87	K9D□150N1 K9D□200N1 K9D□200N2
168		K9D□120N□ K9D□150N2 K9D□150N3 K9D□200N3			

SPECIFICATIONS

Model	Output (W)	Voltage (V)	RATED			Start T. (N·m/kgf·cm)	Starting Current (A)
			Speed (rpm)	Torque (N·m/kgf·cm)	Current (A)		
K9D□60N1	60	12	3000	0.19/1.9	12.0	1.46/14.6	80
K9D□60N2		24			4.6	2.73/27.3	60
K9D□60N3		90			1.4	2.18/21.8	13
K9D□90N1	90	12		0.3/3.0	13.4	1.63/16.3	76
K9D□90N2		24			5.9	3/30	67
K9D□90N3		90			1.6	2.3/23	14
K9D□120N1	120	12		0.39/3.9	17.9	1.75/17.5	90
K9D□120N2		24			7.7	3.95/39.5	85
K9D□120N3		90			1.9	4.39/43.9	25
K9D□150N1	150	12		0.49/4.9	21.1	2.22/22.2	111
K9D□150N2		24			9.0	4.29/42.9	94
K9D□150N3		90			2.5	5/50	30
K9D□200N1	200	12	0.65/6.5	28	1.8/18.0	89	
K9D□200N2		24		18	5.2/52.0	124	
K9D□200N3		90		3.3	5.55/55.5	32	

* □ : SHAFT 형상 (S : STRAIGHT, P : PINION)

GEARHEAD

DIMENSIONS

K9P□B



K9P□BF, BUF



K9P□BU

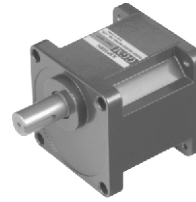

DECIMAL GEARHEAD

K9P10BX

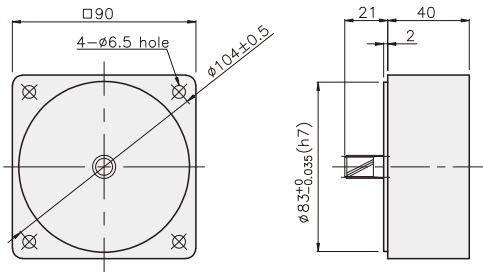

KEY SPEC

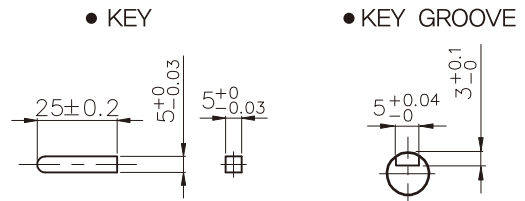

GEARHEAD

K9P□B

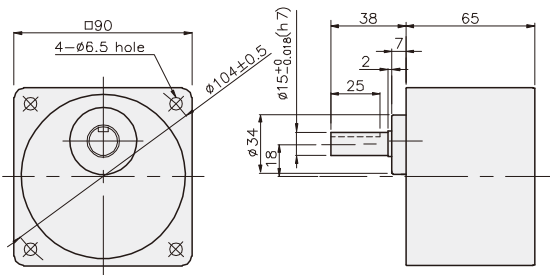

K9P□BF

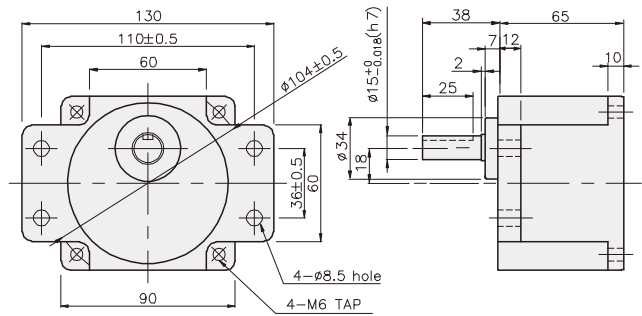

K9P□BU

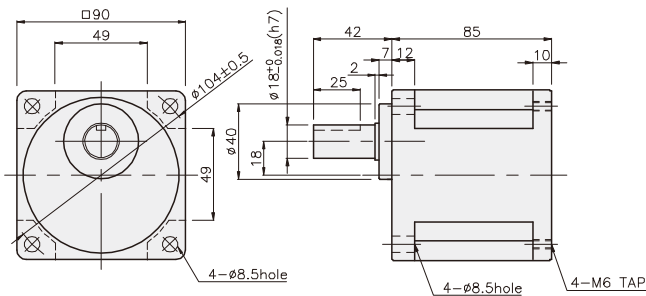

K9P□BUF

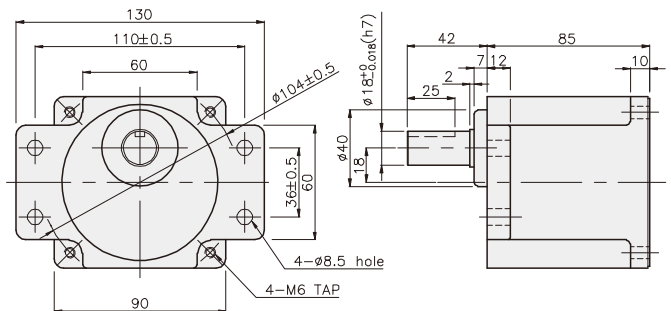

GEARHEAD

DIMENSIONS

적용 BOLT

품번	적용기종	취부 BOLT
01	K9P3~200B	M6 P1,0 X 95
02	K9P10BX	M6 P1,0 X 140

무게

PART	WEIGHT(kg)
K9D□60N□ K9D□90N□	2.21
K9P10BX	0.62
K9P3~10B	1.22
K9P12.5~20B	1.32
K9P25~60B	1.42
K9P75~200B	1.45

K9DP□N□ + K9P□B

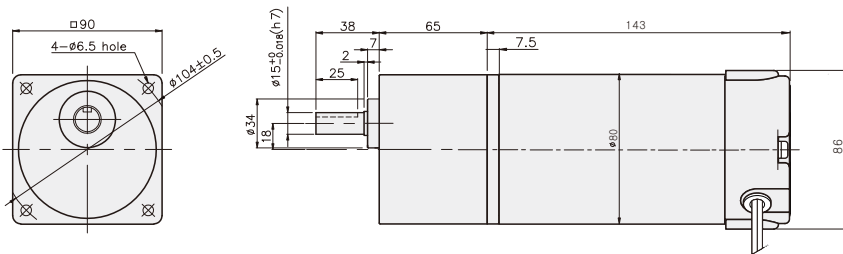

적용 BOLT

품번	적용기종	취부 BOLT
01	K9P3~200BF	M6 P1,0 X 20
02	K9P10BX	M6 P1,0 X 65

무게

PART	WEIGHT(kg)
K9D□60N□ K9D□90N□	2.21
K9P10BX	0.62
K9P3~10BF	1.22
K9P12.5~20BF	1.30
K9P25~60BF	1.42
K9P75~200BF	1.44

K9DP□N□ + K9P□BF

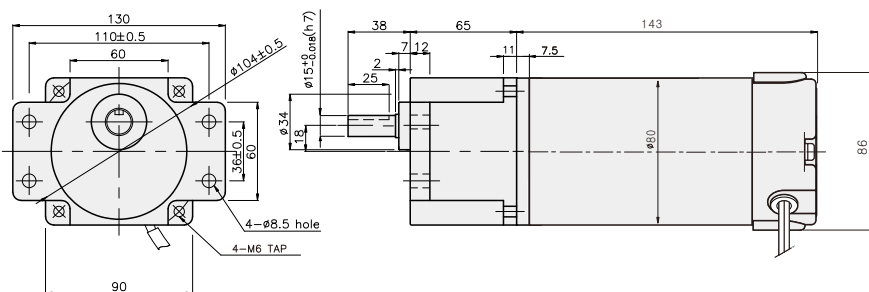

적용 BOLT

품번	적용기종	취부 BOLT
01	K9P3~200BU	M6 P1,0 X 20
02	K9P10BX	M6 P1,0 X 65

무게

PART	WEIGHT(kg)
K9D□60N□ K9D□90N□	2.21
K9P10BX	0.62
K9P3~10BU	1.44
K9P12.5~20BU	1.55
K9P25~60BU	1.69
K9P75~200BU	1.74

K9DP□N□ + K9P□BU

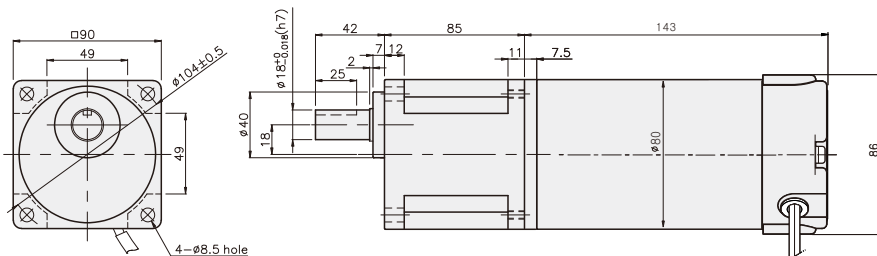

적용 BOLT

품번	적용기종	취부 BOLT
01	K9P3~200BUF	M6 P1,0 X 20
02	K9P10BX	M6 P1,0 X 65

무게

PART	WEIGHT(kg)
K9D□60N□ K9D□90N□	2.21
K9P10BX	0.62
K9P3~10BUF	1.50
K9P12.5~20BUF	1.62
K9P25~60BUF	1.76
K9P75~200BUF	1.82

K9DP□N□ + K9P□BUF

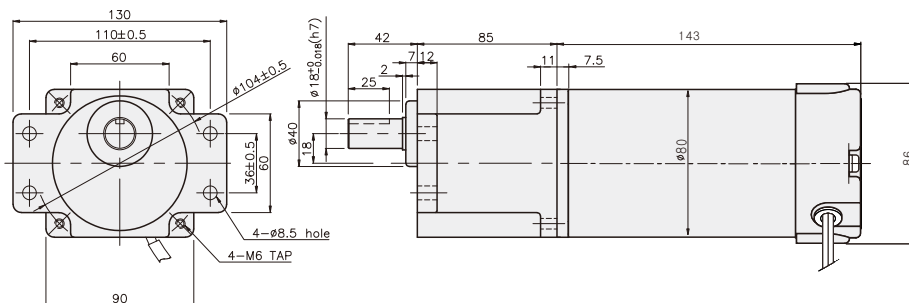

GEARHEAD

DIMENSIONS

적용 BOLT

품번	적용기종	취부 BOLT
01	K9P3~200BU	M6 P1.0 X 20
02	K9P10BX	M6 P1.0 X 65

무게

PART	WEIGHT(kg)
K9D□120N□ K9D□150N3	3.20
K9D□200N3	3.30
K9P10BX	0.62
K9P3~10BU	1.44
K9P12.5~20BU	1.55
K9P25~60BU	1.69
K9P75~200BU	1.74

K9DP□N□ + K9P□BU

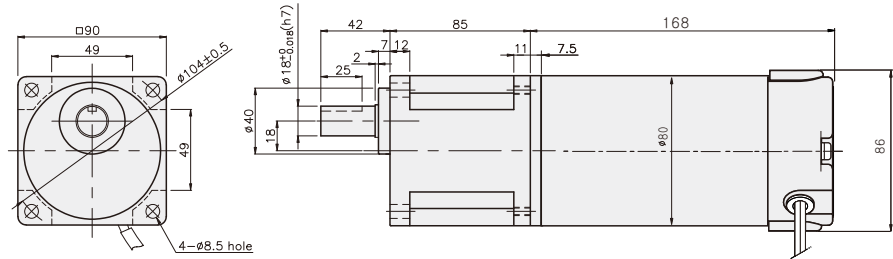

적용 BOLT

품번	적용기종	취부 BOLT
01	K9P3~200BUF	M6 P1.0 X 20
02	K9P10BX	M6 P1.0 X 65

무게

PART	WEIGHT(kg)
K9D□120N□ K9D□150N3	3.20
K9D□200N3	3.30
K9P10BX	0.62
K9P3~10BUF	1.50
K9P12.5~20BUF	1.62
K9P25~60BUF	1.76
K9P75~200BUF	1.82

K9DP□N□ + K9P□BUF

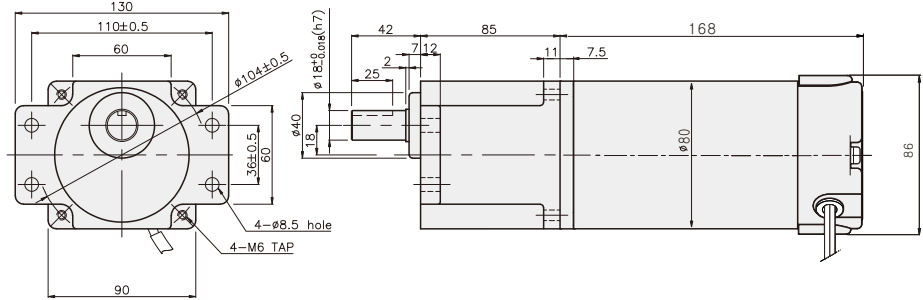

적용 BOLT

품번	적용기종	취부 BOLT
01	K9P3~200BU	M6 P1.0 X 20
02	K9P10BX	M6 P1.0 X 65

무게

PART	WEIGHT(kg)
K9D□150N1	3.50
K9D□150N2	3.20
K9D□200N1	3.70
K9D□200N2	3.40
K9P10BX	0.62
K9P3~10BU	1.44
K9P12.5~20BU	1.55
K9P25~60BU	1.69
K9P75~200BU	1.74

K9DP□N□ + K9P□BU

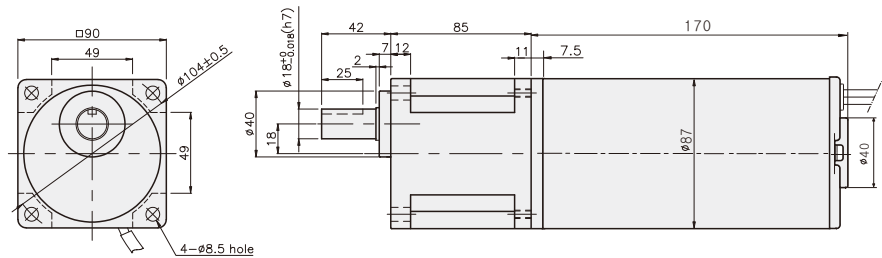

적용 BOLT

품번	적용기종	취부 BOLT
01	K9P3~200BUF	M6 P1.0 X 20
02	K9P10BX	M6 P1.0 X 65

무게

PART	WEIGHT(kg)
K9D□150N1	3.50
K9D□150N2	3.20
K9D□200N1	3.70
K9D□200N2	3.40
K9P10BX	0.62
K9P3~10BUF	1.50
K9P12.5~20BUF	1.62
K9P25~60BUF	1.76
K9P75~200BUF	1.82

K9DP□N□ + K9P□BUF

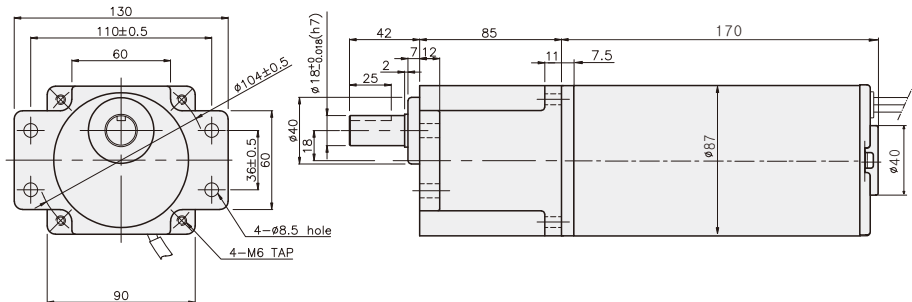

DC MOTOR

RATED TORQUE OF GEARHEAD

● K9P□B, K9P□BF

단위 = 상단 : N·m / 하단 : kgf·cm

Model	Speed (rpm)	1000	833	600	500	400	333	300	240	200	167	150	120	100	83	75	60	50	40	33	30	25	20	17	15
	Ratio	3	3,6	5	6	7,5	9	10	12,5	15	18	20	25	30	36	40	50	60	75	90	100	120	150	180	200
K9DP60N□	0.47	0.57	0.79	0.95	1.18	1.42	1.58	1.77	2.13	2.55	2.84	3.19	3.83	4.60	5.11	6.39	7.66	8.62	10.35	11.50	13.80	17.25	20	20	
	4.7	5.7	7.9	9.5	11.8	14.2	15.8	17.7	21.3	25.5	28.4	31.9	38.3	46.0	51.1	63.9	76.6	86.2	103.5	115.0	138.0	172.5	200	200	
K9DP90N□	0.71	0.85	1.18	1.42	1.77	2.13	2.37	2.66	3.19	3.83	4.26	4.79	5.75	6.90	7.67	9.58	11.50	12.94	15.52	17.25	20	20	20	20	
	7.1	8.5	11.8	14.2	17.7	21.3	23.7	26.6	31.9	38.3	42.6	47.9	57.5	69.0	76.7	95.8	115.0	129.4	155.2	172.5	200	200	200	200	

● K9P□BU, K9P□BUF

단위 = 상단 : N·m / 하단 : kgf·cm

Model	Speed (rpm)	1000	833	600	500	400	333	300	240	200	167	150	120	100	83	75	60	50	40	33	30	25	20	17	15
	Ratio	3	3,6	5	6	7,5	9	10	12,5	15	18	20	25	30	36	40	50	60	75	90	100	120	150	180	200
K9DP90N□	0.71	0.85	1.18	1.42	1.77	2.13	2.37	2.66	3.19	3.83	4.26	4.79	5.75	6.90	7.67	9.58	11.50	12.94	15.52	17.25	20.70	25.87	30	30	
	7.1	8.5	11.8	14.2	17.7	21.3	23.7	26.6	31.9	38.3	42.6	47.9	57.5	69.0	76.7	95.8	115.0	129.4	155.2	172.5	207.0	258.7	300	300	
K9DP120N□	0.95	1.14	1.58	1.89	2.37	2.84	3.15	3.55	4.26	5.11	5.68	6.39	7.67	9.20	10.22	12.78	15.33	17.25	20.70	23.00	27.60	30	30	30	
	9.5	11.4	15.8	18.9	23.7	28.4	31.5	35.5	42.6	51.1	56.8	63.9	76.7	92.0	102.2	127.8	153.3	172.5	207.0	230.0	276.0	300	300	300	
K9DP150N□	1.18	1.42	1.97	2.37	2.96	3.55	3.94	4.44	5.32	6.39	7.10	7.99	9.58	11.50	12.78	15.97	19.17	21.56	25.88	28.75	30	30	30	30	
	11.8	14.2	19.7	23.7	29.6	35.5	39.4	44.4	53.2	63.9	71.0	79.9	95.8	115.0	127.8	159.7	191.7	215.6	258.8	287.5	300	300	300	300	
K9DP200N□	1.58	1.89	2.63	3.15	3.94	4.73	5.26	5.91	7.10	8.52	9.46	10.65	12.78	15.33	17.03	21.29	25.55	28.75	30	30	30	30	30	30	
	15.8	18.9	26.3	31.5	39.4	47.3	52.6	59.1	71.0	85.2	94.6	106.5	127.8	153.3	170.3	212.9	255.5	287.5	300	300	300	300	300	300	

- * GEARHEAD·DECIMAL GEARHEAD는 별매입니다.
- * GEARHEAD의 품명중 □에는 감속비가 들어갑니다.
- * ■ 색이 MOTOR와 같은 방향, 그 외에는 반대 방향입니다.
- * 표의 감속비보다 더 감속하고자 할 경우는 GEARHEAD와 MOTOR 사이에 감속비 10의 DECIMAL GEARHEAD를 설치할 수 있습니다.