

SPEED CONTROL MOTOR - SU SERIES

6W

□60mm

K6□S6N□-SU

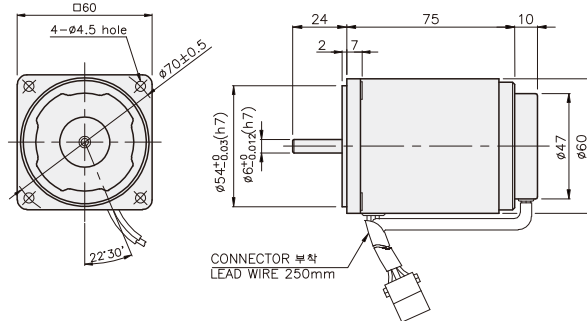

SPECIFICATIONS

6W 연속정격, 4극

Model	Voltage (V)	Frequency (Hz)	Speed (rpm)	Permissible Torque		Start T. (N·m/kgf·cm)	Current (A)	Condenser (μF)
				1200 rpm (N·m/kgf·cm)	90 rpm (N·m/kgf·cm)			
K6I□6NJ-SU	100	50	90 ~ 1400	0.05/0.5	0.03/0.3	0.029/0.29	0.28	3
		60	90 ~ 1700					
K6I□6NU-SU	110	60	90 ~ 1700	0.05/0.5	0.03/0.3	0.03/0.3	0.24	2
	115							
K6I□6NL-SU	200	50	90 ~ 1400	0.05/0.5	0.029/0.29	0.03/0.3	0.19	0.8
		60	90 ~ 1700					
K6I□6NC-SU	220	50	90 ~ 1400	0.05/0.5	0.029/0.29	0.029/0.29	0.2	0.6
		60	90 ~ 1700			0.027/0.27		
		50	90 ~ 1400			0.029/0.29		
		60	90 ~ 1700			0.029/0.29		
K6I□6ND-SU	240	50	90 ~ 1400	0.05/0.5	0.029/0.29	0.03/0.3	0.21	0.5

* □ : SHAFT 형상(S : STRAIGHT, G : PINION)

RATED TORQUE OF GEARHEAD

● 단상 100V/115V

단위 = 상단 : N·m / 하단 : kgf·cm

Model	Ratio	Speed (rpm)																								
		3	3.6	5	6	7.5	9	10	12.5	15	18	20	25	30	36	40	50	60	75	90	100	120	150	180	200	250
K6I□6N□-SU K6G□B(C)	1200	0.12 1.2	0.15 1.5	0.20 2.0	0.24 2.4	0.30 3.0	0.36 3.6	0.41 4.1	0.51 5.1	0.61 6.1	0.73 7.3	0.73 7.3	0.91 9.1	1.09 10.9	1.31 13.1	1.46 14.6	1.64 16.4	1.97 19.7	2.46 24.6	2.95 29.5	3 30	3 30	3 30	3 30	3 30	3 30
	90	0.07 0.7	0.08 0.8	0.12 1.2	0.14 1.4	0.18 1.8	0.21 2.1	0.23 2.3	0.26 2.6	0.32 3.2	0.42 4.2	0.42 4.2	0.53 5.3	0.63 6.3	0.76 7.6	0.85 8.5	0.95 9.5	1.14 11.4	1.43 14.3	1.71 17.1	1.90 19.0	2.28 22.8	2.85 28.5	3 30	3 30	3 30

● 단상 200V/240V

단위 = 상단 : N·m / 하단 : kgf·cm

Model	Ratio	Speed (rpm)																								
		3	3.6	5	6	7.5	9	10	12.5	15	18	20	25	30	36	40	50	60	75	90	100	120	150	180	200	250
K6I□6N□-SU K6G□B(C)	1200	0.12 1.2	0.15 1.5	0.20 2.0	0.24 2.4	0.30 3.0	0.36 3.6	0.41 4.1	0.51 5.1	0.61 6.1	0.73 7.3	0.73 7.3	0.91 9.1	1.09 10.9	1.31 13.1	1.46 14.6	1.64 16.4	1.97 19.7	2.46 24.6	2.95 29.5	3 30	3 30	3 30	3 30	3 30	3 30
	90	0.07 0.7	0.08 0.8	0.12 1.2	0.14 1.4	0.18 1.8	0.21 2.1	0.23 2.3	0.29 2.9	0.35 3.5	0.42 4.2	0.42 4.2	0.53 5.3	0.63 6.3	0.76 7.6	0.85 8.5	0.95 9.5	1.14 11.4	1.43 14.3	1.71 17.1	1.90 19.0	2.28 22.8	2.85 28.5	3 30	3 30	3 30

- * GEARHEAD·DECIMAL GEARHEAD는 별매입니다.
- * GEARHEAD의 품명중 □에는 감속비가 들어갑니다.
- * ■ 색이 MOTOR와 같은 방향, 그 외에는 반대 방향입니다.
- * 표의 감속비보다 더 감속하고자 할 경우는 GEARHEAD와 MOTOR 사이에 감속비 10의 DECIMAL GEARHEAD를 설치할 수 있습니다. 이 경우의 허용 TORQUE는 3 N·m / 30 kgf·cm 입니다.
- * 회전수는 MOTOR의 동기 회전수 (50 Hz : 1500 rpm, 60 Hz : 1800 rpm)를 기준으로 하여 감속비로 나누어서 계산하였습니다. 실제의 회전수는 부하의 크기에 따라서 표시된 수치보다 2~20% 적습니다.

GEARHEAD

CONNECTION DIAGRAMS

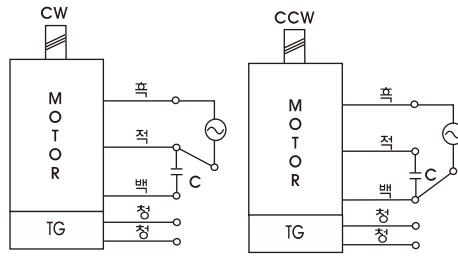

회전방향은 출력축에서 볼 경우

DIMENSIONS

K6G□B(C)



K6IG6N□-SU + K6G□B(C)



DECIMAL GEARHEAD

K6G10BX

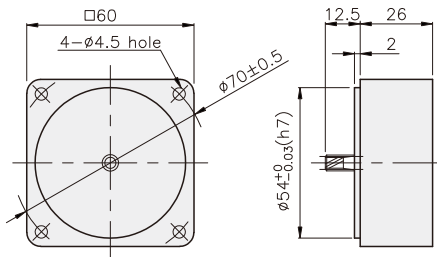

GEARHEAD

K6G□B(C)

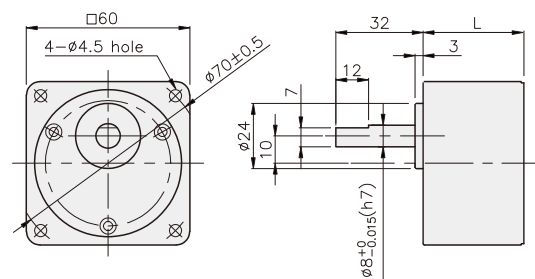

치수도표

품번	L	적용기종	취부 BOLT
01	30	K6G3~18B(C)	M4 P0,7 X 50
02	40	K6G20~250B(C)	M4 P0,7 X 60
03	26	K6G10BX	M4 P0,7 X 85

무게

PART	WEIGHT(kg)	
MOTOR	0,79	
DECIMAL GEARHEAD	0,22	
GEAR HEAD	K6G3~18B(C)	0,26
	K6G20~40B(C)	0,33
	K6G50~250B(C)	0,36

K6IG6N□-SU + K6G□B(C)

