

SPEED CONTROL MOTOR - SU SERIES

180W

□90mm

K9□180F□-SU

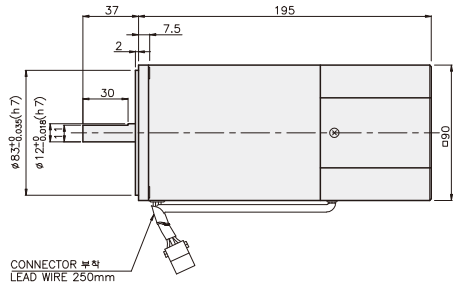
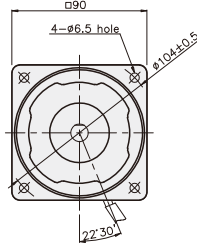

SPECIFICATIONS

180W 연속정격, 4극

Model	Voltage (V)	Frequency (Hz)	Speed (rpm)	Permissible Torque		Start T. (N·m/kgf·cm)	Current (A)	Condenser (μF)
				1200 rpm (N·m/kgf·cm)	90 rpm (N·m/kgf·cm)			
K9□180FJ-SU	100	50	90 ~ 1400	0.9/9	0.35/3.5	0.6/6	5.2	50
			60					
K9□180FU-SU	110	60	90 ~ 1700	0.9/9	0.35/3.5	0.52/5.2	4.8	35
			115					
K9□180FL-SU	200	50	90 ~ 1400	0.9/9	0.3/3	0.5/5	2.2	12
			60					
K9□180FC-SU	220	50	90 ~ 1400	0.9/9	0.3/3	0.45/4.5	2.2	8
			60					
	230	50	90 ~ 1400	1/10	0.33/3.3	0.53/5.3	2.4	
			60					
K9□180FD-SU	240	50	90 ~ 1400	1/10	0.33/3.3	0.6/6	2	8

* □ : SHAFT 형상(S : STARAIGHT, P : PINION)

RATED TORQUE OF GEARHEAD

● 단상 100V/115V

단위 = 상단 : N·m / 하단 : kgf·cm

Model	Ratio	Speed(rpm)																								
		3	3.6	5	6	7.5	9	10	12.5	15	18	20	25	30	36	40	50	60	75	90	100	120	150	180	200	
K9□180F□-SU K9P□BU, BUF	1200	2.19 21.9	2.62 26.2	3.65 36.5	4.37 43.7	5.47 54.7	6.56 65.6	7.29 72.9	8.20 82.0	9.84 98.4	11.81 118.1	13.12 131.2	14.76 147.6	17.71 177.1	21.26 212.6	23.62 236.2	29.52 295.2	30 300	30 300	30 300	30 300	30 300	30 300	30 300	30 300	30 300
	90	0.85 8.5	1.02 10.2	1.42 14.2	1.70 17.0	2.13 21.3	2.55 25.5	2.84 28.4	3.19 31.9	3.83 38.3	4.59 45.9	5.10 51.0	5.74 57.4	6.89 68.9	8.27 82.7	9.19 91.9	11.48 114.8	13.78 137.8	15.50 155.0	18.60 186.0	20.67 206.7	24.80 248.0	30 300	30 300	30 300	30 300

● 단상 200V/240V

단위 = 상단 : N·m / 하단 : kgf·cm

Model	Ratio	Speed(rpm)																								
		3	3.6	5	6	7.5	9	10	12.5	15	18	20	25	30	36	40	50	60	75	90	100	120	150	180	200	
K9□180F□-SU K9P□BU, BUF	1200	200V/220V 50Hz/60Hz	2.19 21.9	2.62 26.2	3.65 36.5	4.37 43.7	5.47 54.7	6.56 65.6	7.29 72.9	8.20 82.0	9.84 98.4	11.81 118.1	13.12 131.2	14.76 147.6	17.71 177.1	21.26 212.6	23.62 236.2	29.52 295.2	30 300	30 300	30 300	30 300	30 300	30 300	30 300	30 300
		230V/50Hz/60Hz 240/50Hz	2.43 24.3	2.92 29.2	4.05 40.5	4.86 48.6	6.08 60.8	7.29 72.9	8.10 81.0	3.19 31.9	10.94 109.4	13.12 131.2	14.58 145.8	16.40 164.0	19.68 197	23.62 236	26.24 262	30 300	30 300	30 300	30 300	30 300	30 300	30 300	30 300	30 300
	90	200V/220V 50Hz/60Hz	0.73 7.3	0.87 8.7	1.22 12.2	1.46 14.6	1.82 18.2	2.19 21.9	2.43 24.3	2.73 27.3	3.28 32.8	3.94 39.4	4.37 43.7	4.92 49.2	5.90 59.0	7.09 70.9	7.87 78.7	9.84 98.4	11.81 118.1	13.29 132.9	15.94 159.4	17.71 177.1	21.26 212.6	26.57 265.7	30 300	30 300
		230V/50Hz/60Hz 240/50Hz	0.80 8.0	0.96 9.6	1.34 13.4	1.60 16.0	2.00 20.0	2.41 24.1	2.41 24.1	3.34 33.4	4.01 40.1	4.81 48.1	5.35 53.5	5.41 54.1	6.50 65.0	7.79 77.9	8.66 86.6	10.83 108.3	12.99 129.2	14.61 146.1	17.54 175.4	19.49 194.9	23.38 233.8	29.23 292.3	30 300	30 300

- * GEARHEAD·DECIMAL GEARHEAD는 별매입니다.
- * GEARHEAD의 품명중 □에는 감속비가 들어갑니다.
- * ■ 색이 MOTOR와 같은 방향, 그 외에는 반대 방향입니다.
- * 표의 감속비보다 더 감속하고자 할 경우는 GEARHEAD와 MOTOR 사이에 감속비 10의 DECIMAL GEARHEAD를 설치할 수 있습니다. 이 경우의 허용 TORQUE는 30 N·m / 300 kgf·cm 입니다.
- * 회전수는 MOTOR의 동기 회전수 (50 Hz : 1500 rpm, 60 Hz : 1800 rpm)를 기준으로 하여 감속비로 나누어서 계산하였습니다. 실제의 회전수는 부하의 크기에 따라서 표시된 수치보다 2~20% 적습니다.

GEARHEAD

CONNECTION DIAGRAMS

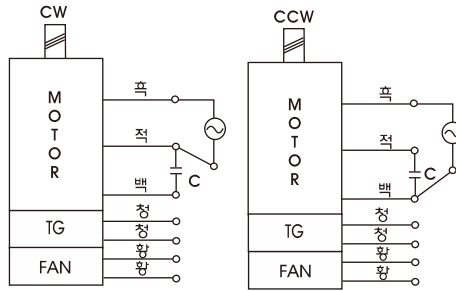

회전방향은 출력축에서 볼 경우

DIMENSIONS

K9P□BU



K9P□BUF



DECIMAL GEARHEAD

K9P10BX

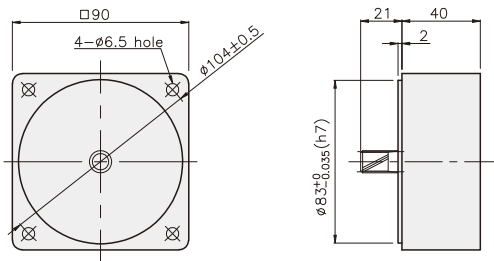

KEY SPEC

● KEY

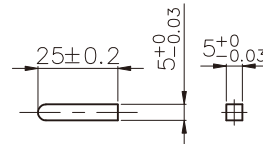

● KEY GROOVE

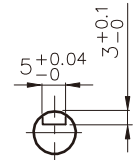

GEARHEAD

K9P□BU

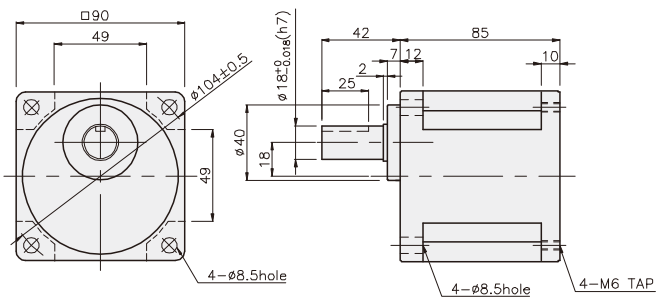

K9P□BUF

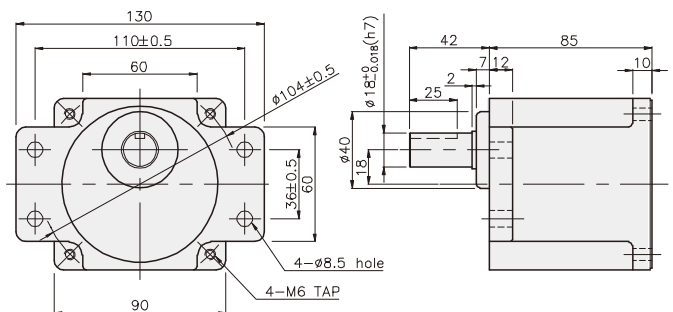

GEARHEAD

DIMENSIONS

K9IP180F□-SU + K9P□BU

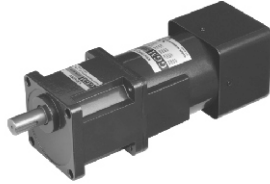

K9IP180F□-SU + K9P□BUF



무게

PART	WEIGHT(kg)
MOTOR	4,24
DECIMAL GEARHEAD	0,62

치수도표

품번	적용기종	취부 BOLT
O1	K9P3~200BU	M6 P1,0 X 20
O2	K9P10BX	M6 P1,0 X 65

무게

PART	WEIGHT(kg)
K9P3~10BU	1,44
K9P12,5~20BU	1,55
K9P25~60BU	1,69
K9P75~200BU	1,74

치수도표

품번	적용기종	취부 BOLT
O1	K9P3~200BUF	M6 P1,0 X 20
O2	K9P10BX	M6 P1,0 X 65

무게

PART	WEIGHT(kg)
K9P3~10BUF	1,50
K9P12,5~20BUF	1,62
K9P25~60BUF	1,76
K9P75~200BUF	1,82

K9IP180F□-SU + K9P□BU

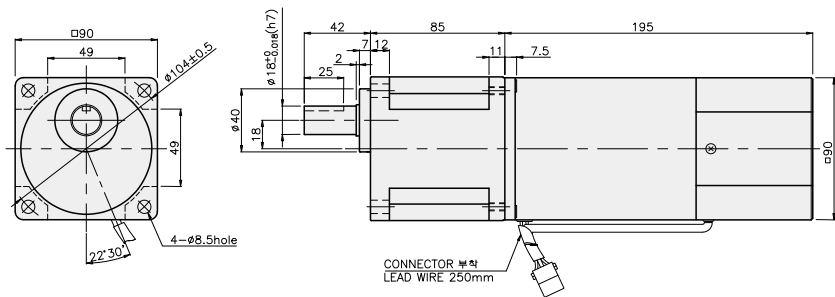

K9IP180F□-SU + K9P□BUF

