

SPEED CONTROL & BRAKE MOTOR

120W

□90mm

SPEED CONTROL & BRAKE MOTOR

K9RS120F□-D

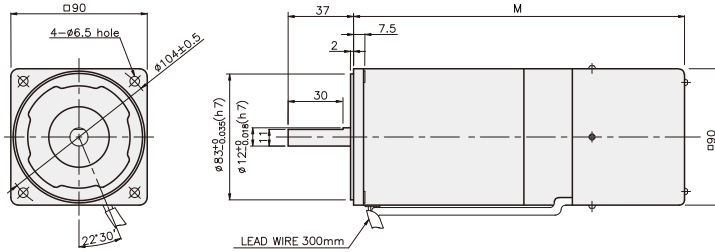

치수도표

품번	M	적용기종
01	236	50Hz
02	216	60Hz

SPECIFICATIONS

120W 30분 정격, 4극

Model	Voltage (V)	Frequency (Hz)	Speed Range (rpm)	Permissible Torque		Start T. (N·m/kgf·cm)	Current (A)	Condenser (μF)	Friction T. (N·m/kgf·cm)
				1200 rpm (N·m/kgf·cm)	90 rpm (N·m/kgf·cm)				
K9R□120FJ-D	100	50	90 ~ 1400	0.85/8.5	0.31/3.1	0.45/4.5	3.6	40	1/10
		60	90 ~ 1700			0.5/5			
K9R□120FU-D	110	60	90 ~ 1700	0.8/8	0.28/2.8	0.4/4	3	25	1/10
	115								
K9R□120FL-D	200	50	90 ~ 1400	0.8/8	0.27/2.7	0.37/3.7	1.4	8.5	1/10
		60	90 ~ 1700	0.78/7.8	0.29/2.9		1.5	8	
K9R□120FC-D	220	50	90 ~ 1400	0.8/8	0.27/2.7	0.37/3.7	1.2	6	1/10
			90 ~ 1700						
	230	60	90 ~ 1400	0.78/7.8	0.29/2.9	0.42/4.2	1.4	7	
			90 ~ 1700						
K9R□120FD-D	240	50	90 ~ 1400	0.8/8	0.27/2.7	0.37/3.7	1.3	6	1/10

* □ : SHAFT 형상(S : STRAIGHT, P : PINION)

RATED TORQUE OF GEARHEAD

● 단상 100V/115V

단위 = 상단 : N·m / 하단 : kgf·cm

Model	Ratio	Speed(rpm)																								
		3	3.6	5	6	7.5	9	10	12.5	15	18	20	25	30	36	40	50	60	75	90	100	120	150	180	200	
K9R□120F□-D K9P□B, BF	1200	100V/50/60Hz	2.07	2.48	3.44	4.13	5.16	6.20	6.89	7.75	9.29	11.15	12.39	13.94	16.73	20.20	20.20	20.20	20.20	20.20	20.20	20.20	20.20	20.20	20.20	20.20
		110V/115V/60Hz	1.94	2.33	3.24	3.89	4.86	5.83	6.48	7.29	8.75	10.50	11.66	13.12	15.75	18.90	20.20	20.20	20.20	20.20	20.20	20.20	20.20	20.20	20.20	20.20
	90	100V/50/60Hz	0.75	0.90	1.26	1.51	1.88	2.26	2.51	2.82	3.39	4.07	4.52	5.08	6.10	7.32	8.14	10.17	12.20	13.73	16.47	18.31	20.20	20.20	20.20	20.20
		110V/115V/60Hz	0.68	0.82	1.13	1.36	1.70	2.04	2.27	2.55	3.06	3.67	4.08	4.59	5.51	6.61	7.35	9.19	11.02	12.40	14.88	16.53	19.84	20.20	20.20	20.20

● 단상 200V/240V

단위 = 상단 : N·m / 하단 : kgf·cm

Model	Ratio	Speed(rpm)																								
		3	3.6	5	6	7.5	9	10	12.5	15	18	20	25	30	36	40	50	60	75	90	100	120	150	180	200	
K9R□120F□-D K9P□B, BF	1200	200V/220V/230V/240V/50Hz	1.94	2.33	3.24	3.89	4.86	5.83	6.48	7.29	8.75	10.50	11.66	13.12	15.75	18.90	20.20	20.20	20.20	20.20	20.20	20.20	20.20	20.20	20.20	20.20
		200V/220V/230V/60Hz	1.90	2.27	3.16	3.79	4.74	5.69	6.32	7.11	8.53	10.24	11.37	12.79	15.35	18.42	20.20	20.20	20.20	20.20	20.20	20.20	20.20	20.20	20.20	20.20
	90	200V/220V/230V/240V/50Hz	0.66	0.79	1.09	1.31	1.64	1.97	2.19	2.46	2.95	3.54	3.94	4.43	5.31	6.38	7.09	8.86	10.63	11.96	14.35	15.94	19.13	20.20	20.20	20.20
		200V/220V/230V/60Hz	0.70	0.85	1.17	1.41	1.76	2.11	2.35	2.64	3.17	3.81	4.23	4.76	5.71	6.85	7.61	9.51	11.42	12.84	15.41	17.12	20.20	20.20	20.20	20.20

- * GEARHEAD-DECIMAL GEARHEAD는 별매입니다.
- * GEARHEAD의 품명중 □에는 감속비가 들어갑니다.
- * ■ 색이 MOTOR와 같은 방향, 그 외에는 반대 방향입니다.
- * 표의 감속비보다 더 감속하고자 할 경우는 GEARHEAD와 MOTOR 사이에 감속비 10의 DECIMAL GEARHEAD를 설치할 수 있습니다. 이 경우의 허용 TORQUE는 20 N·m / 200 kgf·cm 입니다.
- * 회전수는 MOTOR의 동기 회전수 (50 Hz : 1500 rpm, 60 Hz : 1800 rpm)를 기준으로 하여 감속비로 나누어서 계산하였습니다. 실제의 회전수는 부하의 크기에 따라서 표시된 수치보다 2~20% 적습니다.

GEARHEAD

RATED TORQUE OF GEARHEAD

● 단상 100V/115V

단위 = 상단 : N·m / 하단 : kgf·cm

Model Motor/ Gearhead	Ratio Speed(rpm)	3	3.6	5	6	7.5	9	10	12.5	15	18	20	25	30	36	40	50	60	75	90	100	120	150	180	200	
		K9R□120F□-D K9P□BU, BUF	1200	100V 50/60Hz	2.07 20.7	2.48 24.8	3.44 34.4	4.13 41.3	5.16 51.6	6.20 62.0	6.89 68.9	7.75 77.5	9.29 92.9	11.15 111.5	12.39 123.9	13.94 139.4	16.73 167.3	20.08 201	22.31 223	27.88 279	30 300	30 300	30 300	30 300	30 300	30 300
100V/115V 60Hz	1.94 19.4			2.33 23.3	3.24 32.4	3.89 38.9	4.86 48.6	5.83 58.3	6.48 64.8	7.29 72.9	8.75 87.5	10.50 105.0	11.66 116.6	13.12 131.2	15.75 157.5	18.90 189.0	21.00 210	26.24 262	30 300	30 300	30 300	30 300	30 300	30 300	30 300	30 300
90	100V 50/60Hz		0.75 7.5	0.90 9.0	1.26 12.6	1.51 15.1	1.88 18.8	2.26 22.6	2.51 25.1	2.82 28.2	3.39 33.9	4.07 40.7	4.52 45.2	5.08 50.8	6.10 61.0	7.32 73.2	8.14 81.4	10.17 101.7	12.20 122.0	13.73 137.3	16.47 164.7	18.31 183.1	21.97 219.7	27.46 274.6	30 300	30 300
	110V/115V 60Hz		0.68 6.8	0.82 8.2	1.13 11.3	1.36 13.6	1.70 17.0	2.04 20.4	2.27 22.7	2.55 25.5	3.06 30.6	3.67 36.7	4.08 40.8	4.59 45.9	5.51 55.1	6.61 66.1	7.35 73.5	9.19 91.9	11.02 110.2	12.40 124.0	14.88 148.8	16.53 165.3	19.84 198.4	24.80 248.0	29.76 297.6	30 300

● 단상 200V/240V

단위 = 상단 : N·m / 하단 : kgf·cm

Model Motor/ Gearhead	Ratio Speed(rpm)	3	3.6	5	6	7.5	9	10	12.5	15	18	20	25	30	36	40	50	60	75	90	100	120	150	180	200	
		K9R□120F□-D K9P□BU, BUF	1200	200V/220V/230V 240V 50Hz	1.94 19.4	2.33 23.3	3.24 32.4	3.89 38.9	4.86 48.6	5.83 58.3	6.48 64.8	7.29 72.9	8.75 87.5	10.50 105.0	11.66 116.6	13.12 131.2	15.75 157.5	18.90 189.0	21.00 210.0	26.24 262.4	30 300	30 300	30 300	30 300	30 300	30 300
200V/220V/230V 240V 60Hz	1.90 19.0			2.27 22.7	3.16 31.6	3.79 37.9	4.74 47.4	5.69 56.9	6.32 63.2	7.11 71.1	8.53 85.3	10.24 102.4	11.37 113.7	12.79 127.9	15.35 153.5	18.42 184.2	20.47 204.7	25.59 255.9	30 300	30 300	30 300	30 300	30 300	30 300	30 300	30 300
90	200V/220V/230V 240V 50Hz		0.66 6.6	0.79 7.9	1.09 10.9	1.31 13.1	1.64 16.4	1.97 19.7	2.19 21.9	2.46 24.6	2.95 29.5	3.54 35.4	3.94 39.4	4.43 44.3	5.31 53.1	6.38 63.8	7.09 70.9	8.86 88.6	10.63 106.3	11.96 119.6	14.35 143.5	15.94 159.4	19.13 191.3	23.91 239.1	28.70 287.0	30 300
	200V/220V/230V 240V 60Hz		0.70 7.0	0.85 8.5	1.17 11.7	1.41 14.1	1.76 17.6	2.11 21.1	2.35 23.5	2.64 26.4	3.17 31.7	3.81 38.1	4.23 42.3	4.76 47.6	5.71 57.1	6.85 68.5	7.61 76.1	9.51 95.1	11.42 114.2	12.84 128.4	15.41 154.1	17.12 171.2	20.55 205.5	25.69 256.9	30 300	30 300

- * GEARHEAD-DECIMAL GEARHEAD는 별매입니다.
- * GEARHEAD의 품명중 □에는 감속비가 들어갑니다.
- * ■ 색이 MOTOR와 같은 방향, 그 외에는 반대 방향입니다.
- * 표의 감속비보다 더 감속하고자 할 경우는 GEARHEAD와 MOTOR 사이에 감속비 10의 DECIMAL GEARHEAD를 설치할 수 있습니다. 이 경우의 허용 TORQUE는 30 N·m / 300 kgf·cm 입니다.
- * 회전수는 MOTOR의 동기 회전수 (50 Hz : 1500 rpm, 60 Hz : 1800 rpm)를 기준으로 하여 감속비로 나누어서 계산하였습니다. 실제의 회전수는 부하의 크기에 따라서 표시된 수치보다 2~20% 적습니다.

CONNECTION DIAGRAMS

접점 보호를 위해 결선도와 같이 서지(Surge) 전압 흡수용 Cr회로를 접속하여 주십시오.
 $R_o = 5 - 200\Omega$
 $C_o = 0.1 \sim 0.2\mu F$ 200WV(400WV)

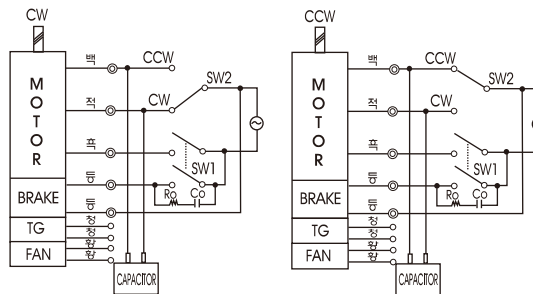

※회전방향은 출력축에서 볼경우

GEARHEAD

DIMENSIONS

K9P□B



K9P□BF, BUF



K9P□BU

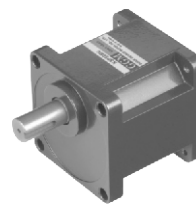

DECIMAL GEARHEAD

K9P10BX

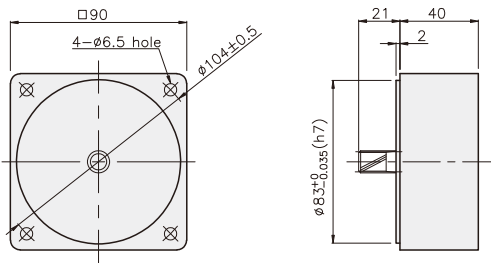

KEY SPEC

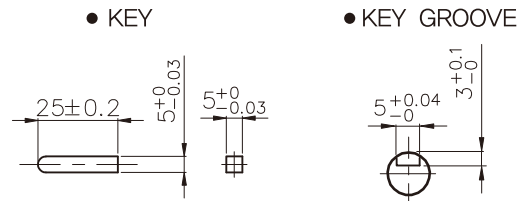

GEARHEAD

K9P□B

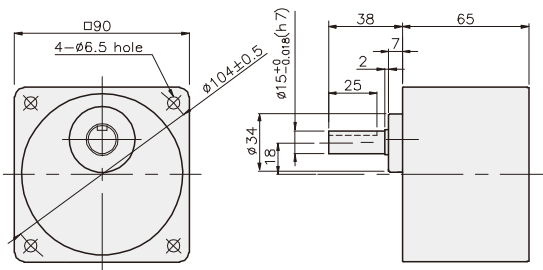

K9P□BF

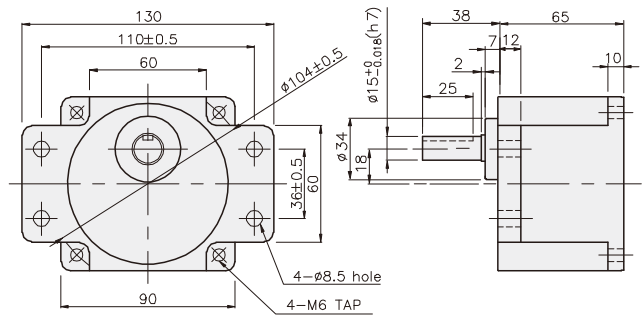

K9P□BU

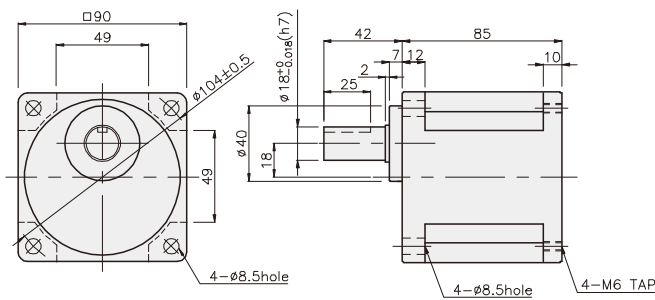

K9P□BUF

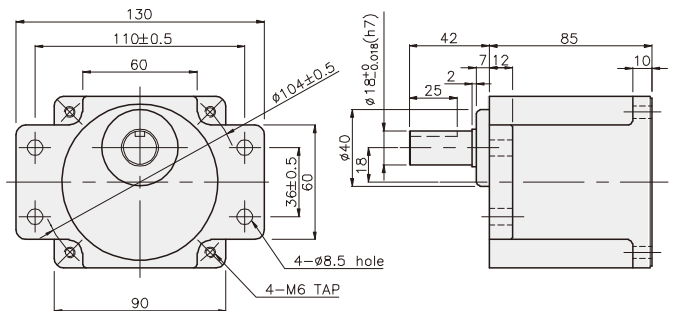

GEARHEAD

DIMENSIONS

K9RP120F□-D + K9P□B



K9RP120F□-D + K9P□BF, BUF



K9RP120F□-D + K9P□BU



K9RP120F□-D + K9P□B

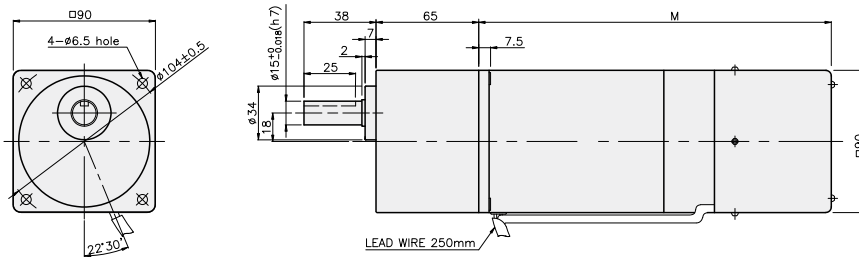

K9RP120F□-D + K9P□BF

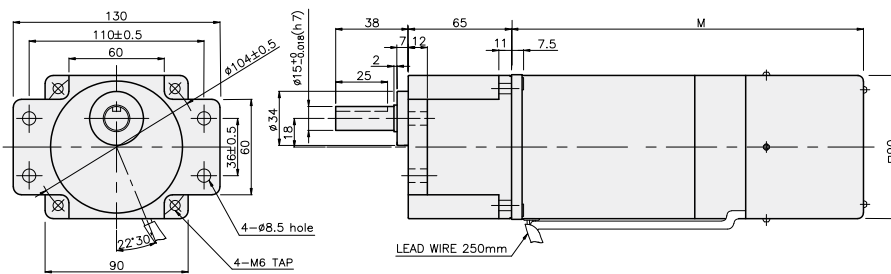

K9RP120F□-D + K9P□BU

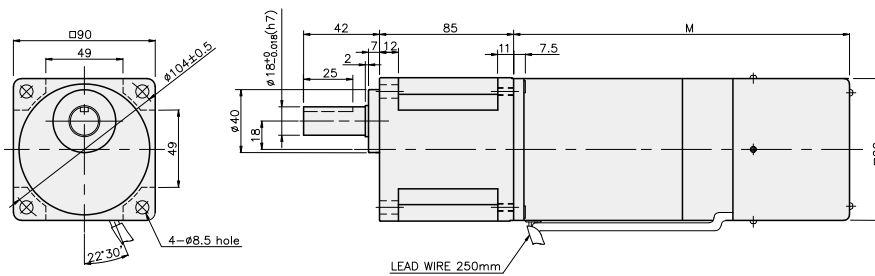

K9RP120F□-D + K9P□BUF

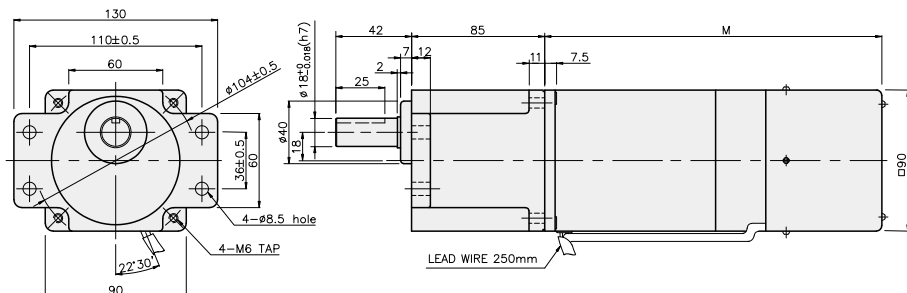

무게

PART	WEIGHT(kg)
MOTOR	3.54
DECIMAL GEARHEAD	0.62

치수도표

품번	M	적용기종
01	236	50Hz
02	216	60Hz

치수도표

품번	적용기종	취부 BOLT
01	K9P3~200B	M6 P1.0 X 95
02	K9P10BX	M6 P1.0 X 140

무게

PART	WEIGHT(kg)
K9P3~10B	1.22
K9P12.5~20B	1.32
K9P25~60B	1.42
K9P75~200B	1.45

치수도표

품번	적용기종	취부 BOLT
01	K9P3~200BF	M6 P1.0 X 20
02	K9P10BX	M6 P1.0 X 65

무게

PART	WEIGHT(kg)
K9P3~10BF	1.22
K9P12.5~20BF	1.30
K9P25~60BF	1.42
K9P75~200BF	1.44

치수도표

품번	적용기종	취부 BOLT
01	K9P3~200BU	M6 P1.0 X 20
02	K9P10BX	M6 P1.0 X 65

무게

PART	WEIGHT(kg)
K9P3~10BU	1.44
K9P12.5~20BU	1.55
K9P25~60BU	1.69
K9P75~200BU	1.74

치수도표

품번	적용기종	취부 BOLT
01	K9P3~200BUF	M6 P1.0 X 20
02	K9P10BX	M6 P1.0 X 65

무게

PART	WEIGHT(kg)
K9P3~10BUF	1.50
K9P12.5~20BUF	1.62
K9P25~60BUF	1.76
K9P75~200BUF	1.82