

BRAKE MOTOR

15W

□70mm

K7RS15N□-B

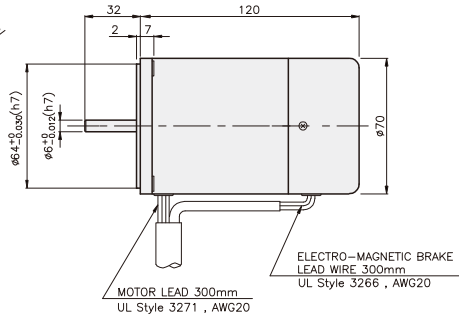
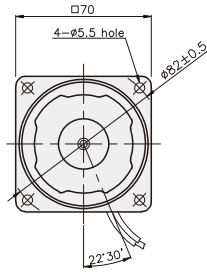

SPECIFICATIONS

15W 30분 정격, 4극

Model	Duty	Voltage (V)	Frequency (Hz)	Current (A)	Start T. (N·m/kgf·cm)	Rated T. (N·m/kgf·cm)	Speed (rpm)	Condenser (μF)	Friction T. (N·m/kgf·cm)	
K7R□15NJ-B	단상 30분	100	50	0.46	0.115/1.15	0.12/1.2	1250	7	0.2/2	
			60	0.48		0.1/1	1500			
K7R□15NU-B		110	60	0.47	0.12/1.2	0.1/1	1500	6	0.2/2	
		115		0.49	0.125/1.25					
K7R□15NL-B		200	50	0.23	0.115/1.15	0.122/1.22	1250	2	0.2/2	
			60	0.28		0.1/1	1500			
K7R□15NC-B		220	50	0.21	0.115/1.15	0.12/1.2	1250	1.5	0.2/2	
			60	0.24		0.1/1	1500			
			230	50	0.25	0.125/1.25	0.12/1.2			1250
				60	0.24		0.1/1			1500
K7R□15ND-B		240	50	0.25	0.13/1.3	0.12/1.2	1250	1.5	0.2/2	

* □ : SHAFT 형상(S : STRAIGHT, G : PINION)

RATED TORQUE OF GEARHEAD

● 50Hz

단위 = 상단 : N·m / 하단 : kgf·cm

Model Motor/ Gearhead	Speed(rpm)	500	416	300	250	200	166	150	120	100	83	75	60	50	41	37	30	25	20	16	15	12.5	10	8.3	7.5
	Ratio	3	3.6	5	6	7.5	9	10	12.5	15	18	20	25	30	36	40	50	60	75	90	100	120	150	180	200
K7R□15N□-B K7G□B(C)	0.29	0.35	0.49	0.58	0.73	0.87	0.97	1.22	1.46	1.75	1.75	2.19	2.62	3.15	3.50	3.94	4.72	5	5	5	5	5	5	5	5
	2.9	3.5	4.9	5.8	7.3	8.7	9.7	12.2	14.6	17.5	17.5	21.9	26.2	31.5	35.0	39.4	47.2	50	50	50	50	50	50	50	50

● 60Hz

단위 = 상단 : N·m / 하단 : kgf·cm

Model Motor/ Gearhead	Speed(rpm)	600	500	360	300	240	200	180	144	120	100	90	72	60	50	45	36	30	24	20	18	15	12	10	9
	Ratio	3	3.6	5	6	7.5	9	10	12.5	15	18	20	25	30	36	40	50	60	75	90	100	120	150	180	200
K7R□15N□-B K7G□B(C)	0.24	0.29	0.41	0.49	0.61	0.73	0.81	1.01	1.22	1.46	1.46	1.82	2.19	2.62	2.92	3.28	3.94	4.92	5	5	5	5	5	5	5
	2.4	2.9	4.1	4.9	6.1	7.3	8.1	10.1	12.2	14.6	14.6	18.2	21.9	26.2	29.2	32.8	39.4	49.2	50	50	50	50	50	50	50

- * GEARHEAD-DECIMAL GEARHEAD는 별매입니다.
- * GEARHEAD의 품명중 □에는 감속비가 들어갑니다.
- * 색이 MOTOR와 같은 방향, 그 외에는 반대 방향입니다.
- * 표의 감속비보다 더 감속하고자 할 경우는 GEARHEAD와 MOTOR 사이에 감속비 10의 DECIMAL GEARHEAD를 설치할 수 있습니다. 이 경우의 허용 TORQUE는 5 N·m / 50 kgf·cm 입니다.
- * 회전수는 MOTOR의 동기 회전수 (50 Hz : 1500 rpm, 60 Hz : 1800 rpm)를 기준으로 하여 감속비로 나누어서 계산하였습니다. 실제의 회전수는 부하의 크기에 따라서 표시된 수치보다 2~20% 적습니다.

GEARHEAD

CONNECTION DIAGRAMS

접점 보호를 위해 결선도와 같이 서지(Surge) 전압 흡수용 Cr회로를 접속하여 주십시오.
 $R_o = 5 - 200\Omega$
 $C_o = 0.1 \sim 0.2\mu F$ 200WV(400WV)

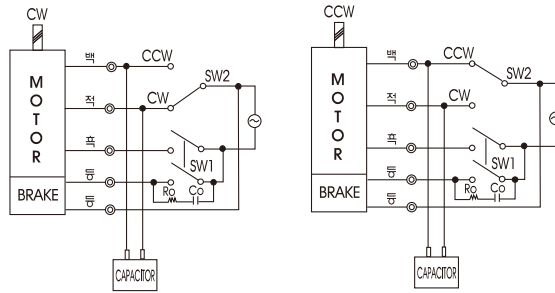

※ 회전방향은 출력축에서 볼 경우

DIMENSIONS

K7G□B(C)



K7RG15N□-B + K7G□B(C)



DECIMAL GEARHEAD

K7G10BX

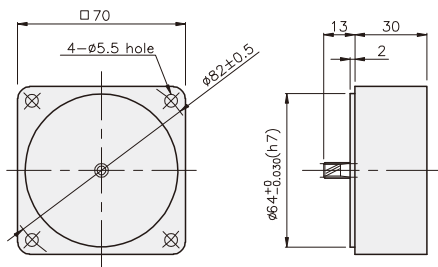

GEARHEAD

K7G□B(C)

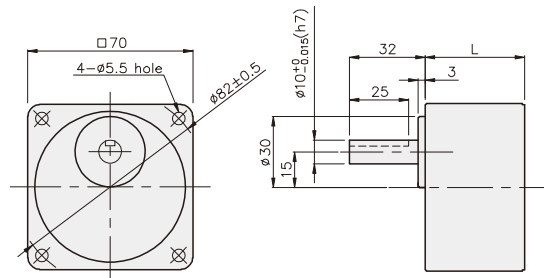

KEY SPEC

- KEY
- KEY GROOVE

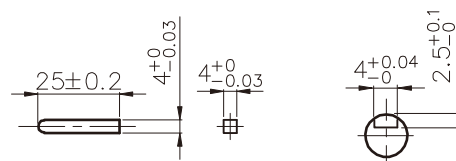

치수도표

품번	L	적용기종	취부 BOLT
01	32	K7G3~18B(C)	M4 P0.8 X 50
02	42	K7G20~200B(C)	M4 P0.8 X 65
03	30	K7G10BX	M4 P0.8 X 90

무게

PART	WEIGHT(kg)	
MOTOR	1.30	
DECIMAL GEARHEAD	0.32	
GEAR HEAD	K7G3-18B(C)	0.38
	K7G20-40B(C)	0.46
	K7G50-200B(C)	0.51

K7RG15N□-B + K7G□B(C)

