



OUTPUT	MODEL	TYPE
40W DC12V,24V90V 3000RPM ( $\varnothing$ 80mm)	DG80-F012040B DG80-F024040B DG80-F090040B	DG80 시리즈 기어축 DC 모터+박스형 기어박스

## DIMENSIONS

DECIMAL GEARHEAD  
K8G10BX

GEAR HEAD  
K8G□B(C)

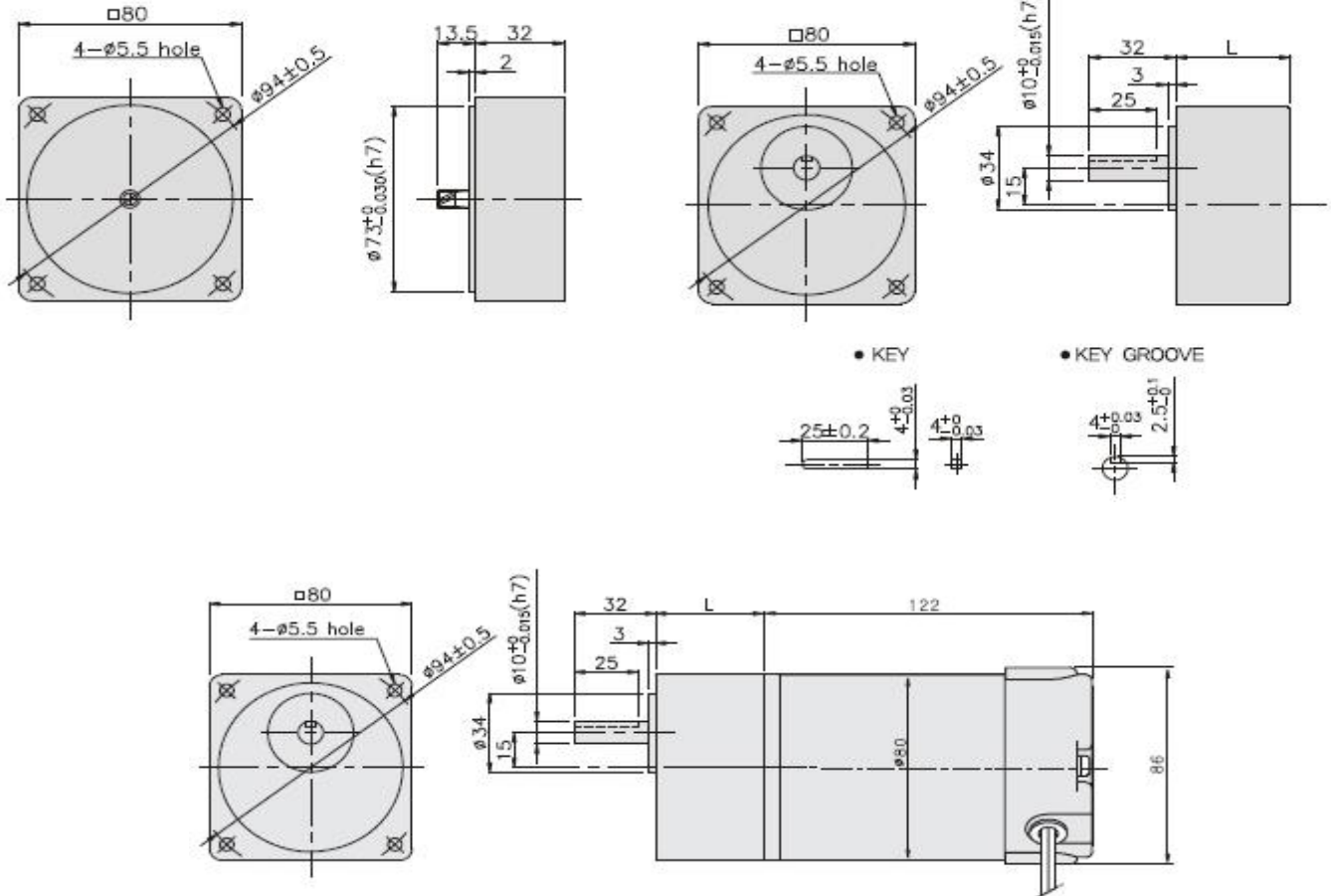

치수도표

품번	L	적용기종	감속 비율
기어박스	32	K8G3~18C	3:1 ~ 18:1
기어박스	42	K8G20~250C	20:1 ~ 250:1
중간기어박스	32	K8G10BX	10 배수 만큼 증가

무게

PART	WEIGHT(kg)
MOTOR	1.76
DECIMAL GEARHEAD	0.46
GEARHEAD	
K8G3~18C	0.51
K8G20~40C	0.64
K8G50~250C	0.70

## SPECIFICATIONS

▶ 40W

Model	output (W)	Voltage (V)	RATED			NO LOAD Speed (rpm)	WEIGHT (kg)
			Speed (rpm)	Torque (N·m/kgf·cm)	Current (A)		
DG80-F012040B	40	12	3000	0.13/1.3	4.7	3500	1.76
DG80-F024040B		24					
DG80-F090040B		90					

\* SHAFT 형상 ( S: 동근축 D-CUT, G: 기어축)

## RATED TORQUE OF GEARHEAD

▶ DC12V (□=1), 24V (□=2), 90V (□=3) 40W 3000RPM 모터 + 기어박스

단위=상단:N·m/하단:kgf·cm

MODEL	SPEED (rpm)	1000	833	600	500	400	333	300	240	200	167	150	120	100	83	75	60	50	40	33	30	25	20	17	15	12
MOTOR / GEARHEAD	Ratio	3	3.6	5	6	7.5	9	10	12.5	15	18	20	25	30	36	40	50	60	75	90	100	120	150	180	200	250
DG80-F□040B K8G □ C		0.32	0.38	0.53	0.63	0.79	0.95	1.05	1.31	1.58	1.89	1.89	2.37	2.84	3.41	3.78	4.26	5.11	6.39	7.66	8	8	8	8	8	8
		3.2	3.8	5.3	6.3	7.9	9.5	10.5	13.1	15.8	18.9	18.9	23.7	28.4	34.1	37.8	42.6	51.1	63.9	76.6	80	80	80	80	80	80

※ GEARHEAD의 품명중 □에는 감속비가 들어갑니다.

※ ■ 색이 MOTOR와 같은 방향, 그외에는 반대 방향입니다.

※ 표의 감속비보다 더 감속하고자 할 경우는 GEARHEAD와 MOTOR 사이에 감속비 10의 DECIMAL GEARHEAD(중간기어)를 설치할 수 있습니다.

※ GEARHEAD의 설계상 보증 토크값이 80KgfcM이므로 실제 출력 토크값이 더 큰 경우에도 80KgfcM 이상 표기하지 않았습니다.

※ 회전수는 MOTOR의 정격 부하시 최대 회전수 3000rpm을 기준으로 하여 감속비로 나누어서 계산하였습니다.

선택 옵션 - 모터고정대



### DOWNLOAD

<b>DIMENSION</b>	CAD	3D
	PDF	

MODEL	적용제품	특성
K8B (□80mm)	표준형 모터 □80mm GEARHEAD : K8G□C (B)	중량 120g 재질 AL

### DIMENSIONS

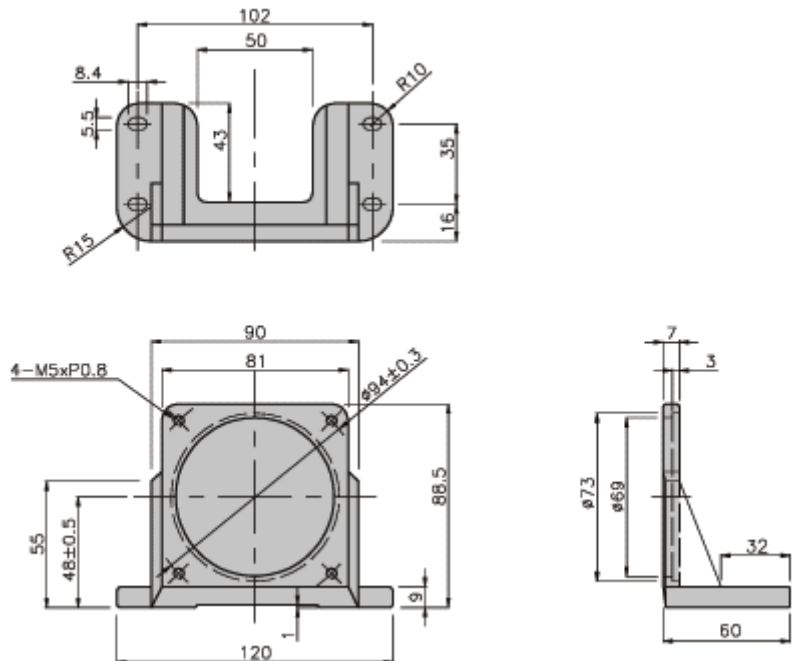



OUTPUT	MODEL	TYPE
40W DC12V,24V90V 3000RPM ( $\varnothing$ 80mm)	DG80-F012040B DG80-F024040B DG80-F090040B	DG80 시리즈 기어축 DC 모터+박스형 기어박스

### DIMENSIONS

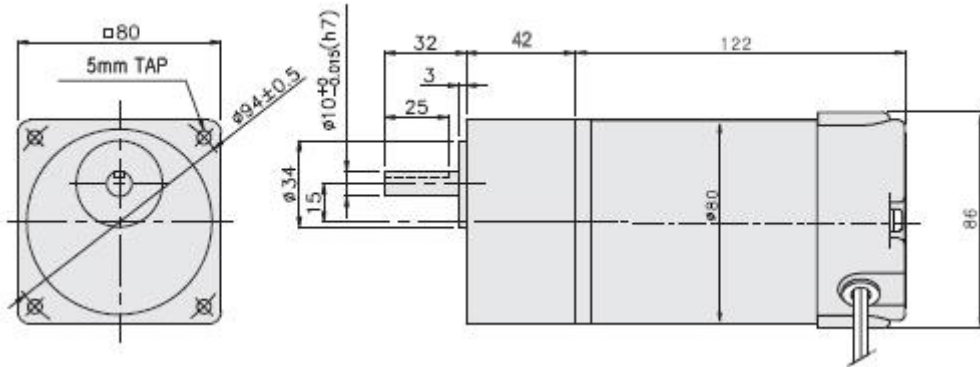

### RATED TORQUE OF GEARHEAD

#### ▶ 40W + 기어박스 1/20

Model	output (W)	Voltage (V)	RATED			기어박스 체결방식	WEIGHT (kg)
			Speed (rpm)	Torque (N·m/kgf·cm)	Current (A)		
DG80-F012040B + SS8KA20B	40	12	150	1.89/18.9	4.7	5mm TAP BOLT	2.4
DG80-F024040B + SS8KA20B		24					
DG80-F090040B + SS8KA20B		90					

#### ▶ 40W + 기어박스 1/40

Model	output (W)	Voltage (V)	RATED			기어박스 체결방식	WEIGHT (kg)
			Speed (rpm)	Torque (N·m/kgf·cm)	Current (A)		
DG80-F012040B + SS8KA40B	40	12	75	3.78/37.8	4.7	5mm TAP BOLT	2.4
DG80-F024040B + SS8KA40B		24					
DG80-F090040B + SS8KA40B		90					

※ SHAFT 형상 ( S: 동근축 D-CUT, G: 기어축)



DOWNLOAD		
<b>DIMENSION</b>	CAD	3D
<b>CATALOGUE</b>	PDF	

MODEL	적용제품	특성
K8B (□80mm)	표준형 모터 □80mm GEARHEAD : K8G□C (B)	중량 120g 재질 AL

### DIMENSIONS

