

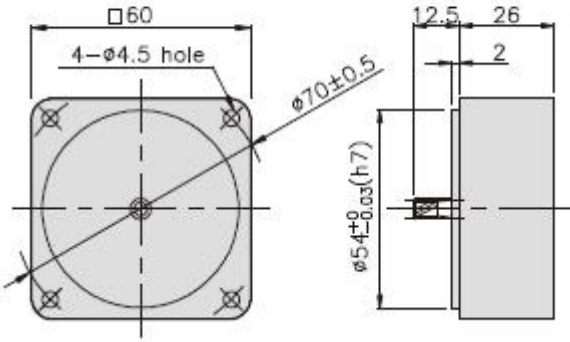

OUTPUT	MODEL	TYPE
20W DC12V,24V,90V 3000RPM (\varnothing 60mm)	DG60-F012020B DG60-F024020B DG60-F090020B	DG60 시리즈 기어축 DC 모터+박스형기어박스

DIMENSIONS

DECIMAL GEARHEAD
K6G10BX \square



GEARHEAD
K6G \square B(C)

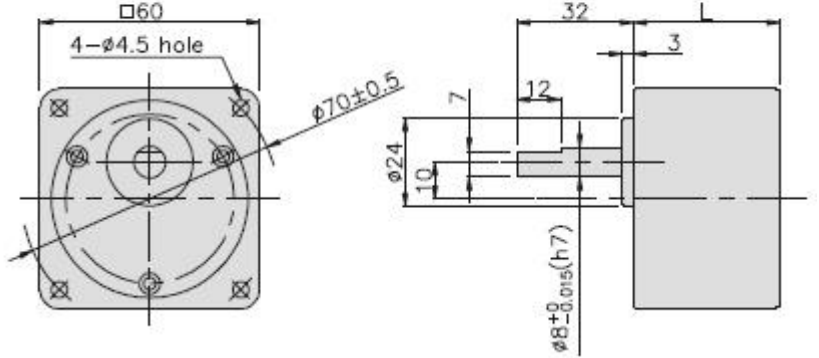

DG60-F \square 020B + K6G \square C

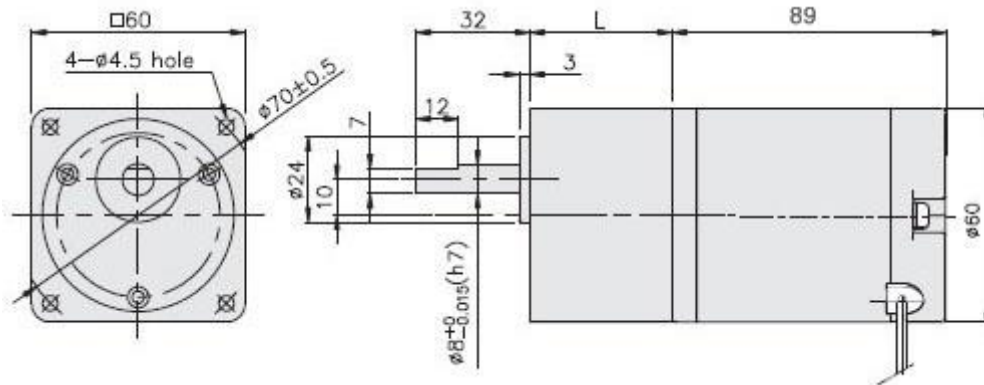

치수도표

품번	L	적용기종	감속 비율
기어박스	30	K6G3~18C	3:1 ~ 18:1
기어박스	40	K6G20~250C	20:1 ~ 250:1
중간기어박스	26	K6G10BX	10 배수 만큼 증가

무게

PART	WEIGHT(kg)
MOTOR	0.8
DECIMAL GEARHEAD	0.22
GEARHEAD	
K6G3~18C	0.26
K6G20~40C	0.33
K6G50~250C	0.36

SPECIFICATIONS

▶ 20W

Model	output (W)	Voltage (V)	RATED			NO LOAD Speed (rpm)	WEIGHT (kg)	
			Speed (rpm)	Torque (N·m/kgf·cm)	Current (A)			
DG60-F012020B	20	12	3000	0.06/0.6	3.1	3500	0.8	
DG60-F024020B		24						1.6
DG60-F090020B		90						0.4

※ SHAFT 형상 (D : 동근축 D-CUT, G : 기어축)

