

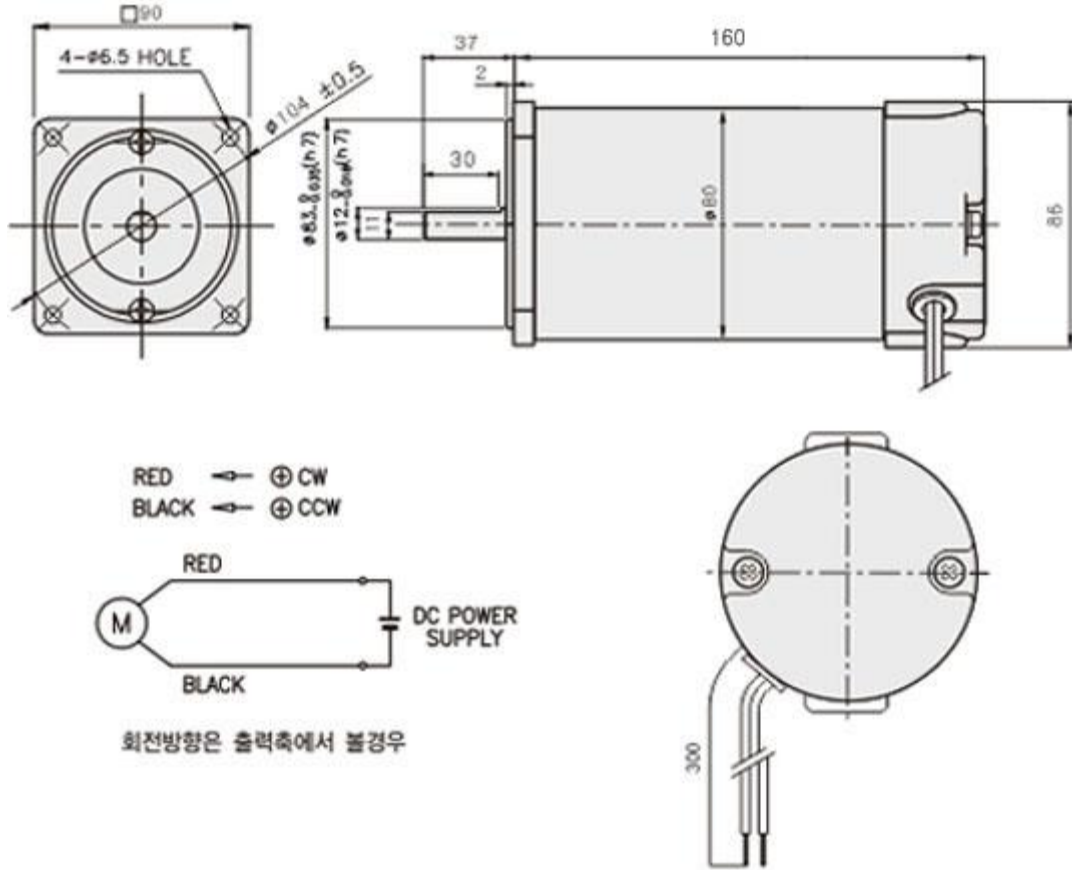

OUTPUT	MODEL	TYPE
150W DC12V 3000RPM (□ 90mm)	DD90-F012150B	DD90 씨리즈 (동근축 DC 모터)

DIMENSIONS



SPECIFICATIONS

▶ 150W

Model	output (W)	Voltage (V)	RATED			Start T. (N·m/kgf·cm)	WEIGHT (kg)
			Speed (rpm)	Torque (N·m/kgf·cm)	Current (A)		
DD90-F012150B	150	12	3000	0.49/4.9	21.1	2.22/22.2	3

※ SHAFT 형상 (D: 동근축 D-CUT, G: 기어축)

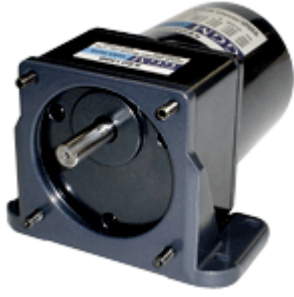

MODEL	적용제품	특성
K9B-M6 (□90mm)	표준형 모터 □90mm GEARHEAD : K9G□C, K9P□B	중량 270g 재질 AL

DIMENSIONS

